

PLAN VIEW

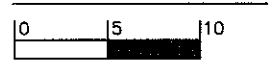

UTILITY LOCATIONS SHOWN ARE APPROXIMATE

NORTHEAST CORNER OF CONCRETE GENERATOR FOUNDATION IS 7.0-ft WEST AND 11.0-ft SOUTH OF THE DRYWELL LID, SEE SEE DETAIL 1

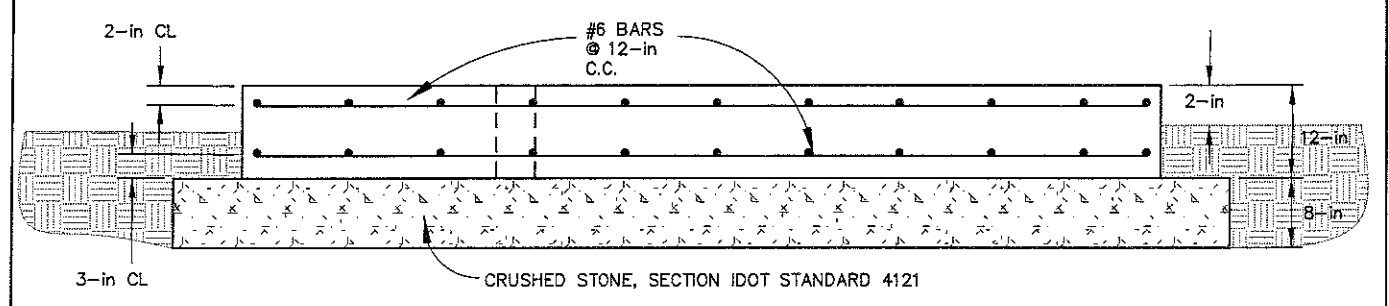
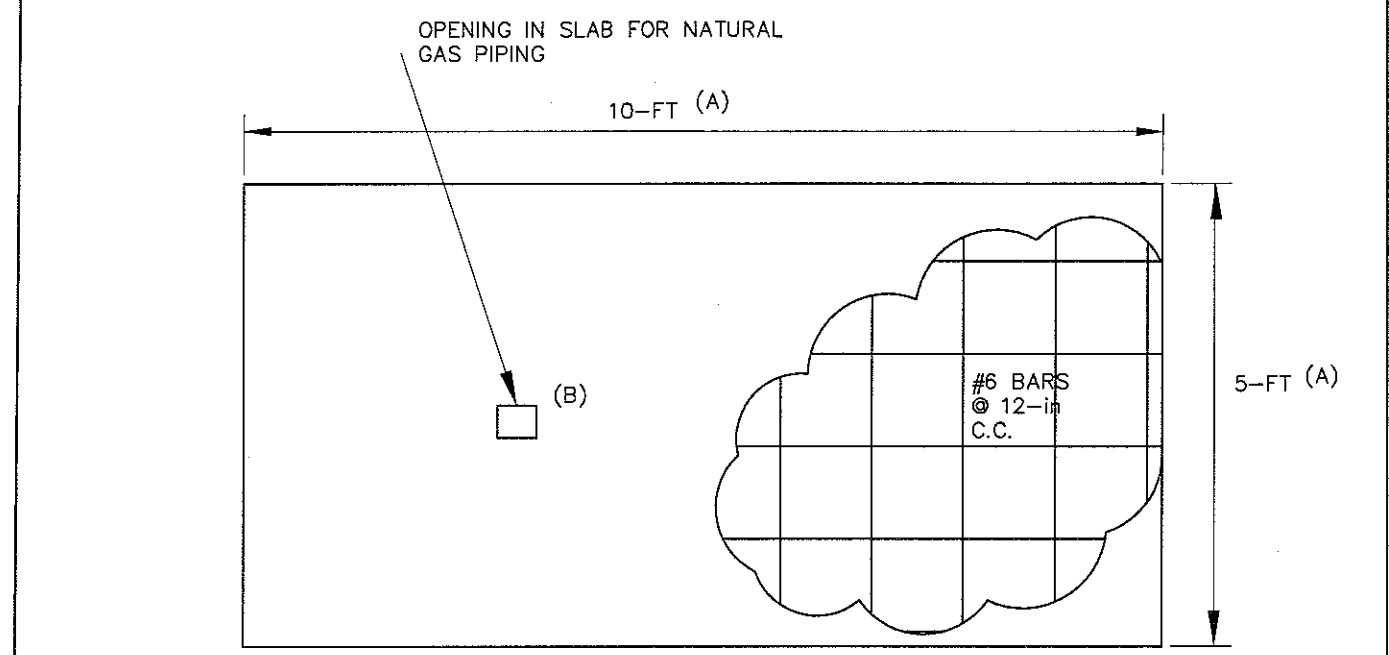

DETAIL 1-FOUNDATION

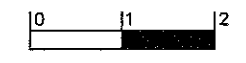

- NOTES:**
- (A) DIMENSIONS ARE APPROXIMATE. FINAL DIMENSIONS WILL BE DETERMINED BY GENERATOR PROVIDED.
 - (B) LOCATION TO BE DETERMINED BY GENERATOR MANUFACTURER.
 - (C) AUTOMATIC TRANSFER SWITCH AND CONTROLLER SHALL BE MOUNTED ON MODULAR STRUT IN GENERAL LOCATION SHOWN. ENSURE LOCATION DOES NOT INTERFERE WITH MAINTENANCE ACCESS.
 - (D) CONTROLLER SHALL BE MOUNTED IN NEMA 4X ENCLOSURE.

NO.	REVISION DESCRIPTION	APPROVED	DATE